



Gebrauchsanweisung , Notice d'utilisation et d'installation, Istruzioni per l'uso

EFC 6410-6414-6405-9405-9410-9414

EFC 650-950-640

CH 1200-900-600

User manual , Installatie- en gebruiksaanwijzing, Manual de Instruções

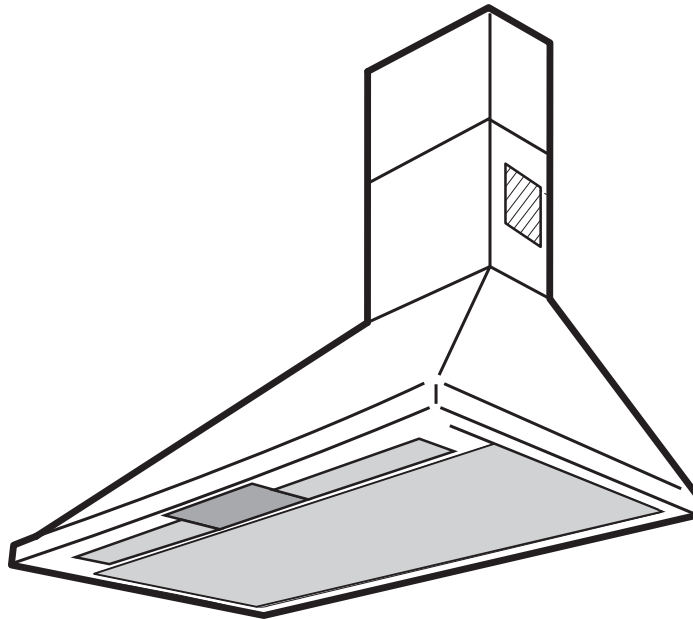

D

F

I

UK

NL

P

Safety warnings	30
For the installer	30
For the user	30
Description of the appliance	31
Extractor version	31
Filter Version	31
Control Panel	32
Correct ventilation	32
Maintenance and care	33
Cleaning the hood	33
Metal grease filter	33
Removing the metal grease filter	33
Charcoal filter	34
Changing the light bulb	34
What to do if	35
Special accessories*	35
Technical Specifications	35
Technical assistance service	36
Guarantee Conditions	37
Installation	38
Unpacking	38
Placement	38
Electrical connection	38
Wall unit mounting	39

Before you use the cooker hood we recommend that you read through the whole user manual giving a direct description of the cooker hood and its functions.

To avoid the risks, that are always present when you use a product driven by electricity, it is important that the cooker hood is installed correctly and that you read the safety instructions carefully to avoid misuse and hazard. Save the instruction manual and keep it available at use of the cooker hood.



Safety warnings

For the installer

- When used as an extractor unit, the hood must be fitted with a 120mm diameter hose.
- **When installing the hood, make sure you respect the following minimum distance from the top edge of the cooking hob/ring surfaces:**

electric cookers	650 mm
gas cookers	750 mm
coal and oil cookers	800 mm min.
- The national Standard on fuel-burning systems specifies a maximum depression of 0.04 mbar in such rooms.
- The air outlet must not be connected to chimney flues or combustion gas ducts. The air outlet must under no circumstances be connected to ventilation ducts for rooms in which fuel-burning appliances are installed.
- The air outlet installation must comply with the regulations laid down by the relevant authorities.
- When the unit is used in its extractor version, a sufficiently large ventilation hole must be provided, with dimensions that are approximately the same as the outlet hole.
- National and regional building regulations impose a number of restrictions on using hoods and fuel-burning appliances connected to a chimney, such as coal or oil room-heaters and gas fires, in the same room.
- Hoods can only be used safely with appliances connected to a chimney if the room and/or flat (air/environment combination) is ventilated from outside using a suitable ventilation hole approximately 500-600 cm² large to avoid the possibility of a depression being created during operation of the hood.
- If you have any doubts, contact the relevant controlling authority or building inspector's office.
- Since the rule for rooms with fuel burning appliances is "outlet hole of the same size as the ventilation hole", a hole of 500-600 cm², which is to say a larger hole, could reduce the performance of the extractor hood.
- If the hood is used in its filtering function, it will operate simply and safely in the above conditions without the need for any of the aforementioned measures.

- When the hood is used in its extractor function, the following rules must be followed to obtain optimal operation:
 - short and straight outlet hose
 - keep bends in outlet hose to a minimum
 - never install the hoses with an acute angle, they must always follow a gentle curve.
 - keep the hose as large as possible (preferably the same diameter as the outlet hole).
- Failure to observe these basic instructions will drastically reduce the performance and increase the noise levels of the extractor hood.

For the user

- **The cooker hood is designed to extract unpleasant odours from the kitchen, it will not extract steam.**
- Always cover heating elements, to prevent excessive heat from damaging the appliance. In the case of oil, gas and coal fired cookers it is essential to avoid open flames.
- Also, when frying, keep the deep frying pan on the cooker top/cooker under careful control.
- The hot oil in the frying pan might ignite due to overheating.
- The risk of self-ignition increases when the oil being used is dirty.
- It is extremely important to note that overheating can cause a fire.
- **Never carry out any flambé cooking under the hood.**
- **Always disconnect the unit from the power supply before carrying out any work on the hood, including replacing the light bulb** (take the cartridge fuse out of the fuse holder or switch off the automatic circuit breaker).
- **It is very important to clean the hood and replace the filter at the recommended intervals. Failure to do so could cause grease deposits to build up, resulting in a fire hazard.**
- The appliance is not intended for use by young children or infirm persons without supervision.
- Young children should be supervised to ensure that they do not play with the appliance.
- **WARNING** - Ensure that the appliance is switched off before replacing the lamp to avoid the possibility of electric shock.

Description of the appliance

- The hood is supplied as an extractor unit and can also be used with a filtering function by fitting one charcoal filter.
- You will need an original ELECTROLUX charcoal filter for this function (Available from your local ELECTROLUX Service Force Centre).

Attention! Certain models are already equipped with charcoal filters. The charcoal filters are attached to one side of the polystyrene protection panels in the packaging and should be fitted into place prior to using the cooker hood in the recirculation version.

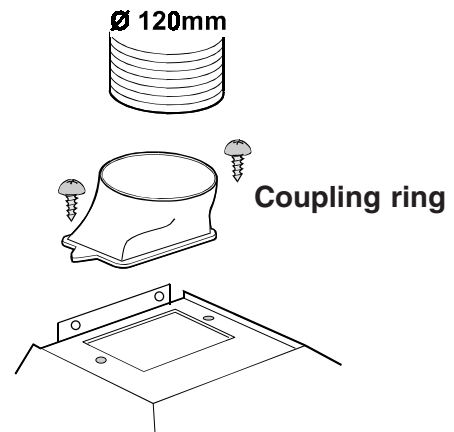

Fig. 1

Extractor version

- In this version fumes are extracted to the outside via a hose connected to the coupling ring. **Fig. 1.**
- In order to obtain the best performance the hose should have a diameter equal to the outlet hole.

Recirculation Version

- The air is filtered through a charcoal filter and returned to the kitchen through the top grill of the outlet pipe.
- Fix the deflector using 2 screws $\varnothing 3,5 \times 6,5$ mm. **Fig. 2.**

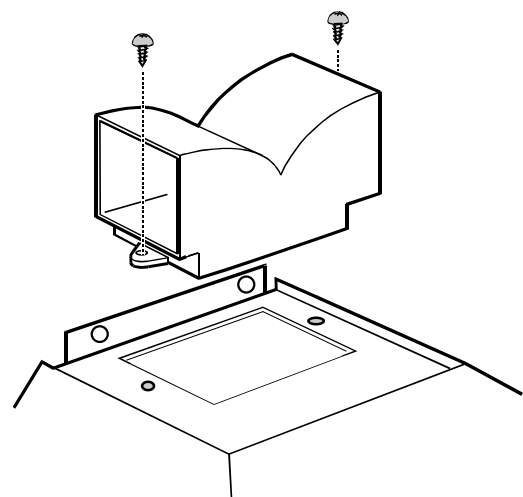
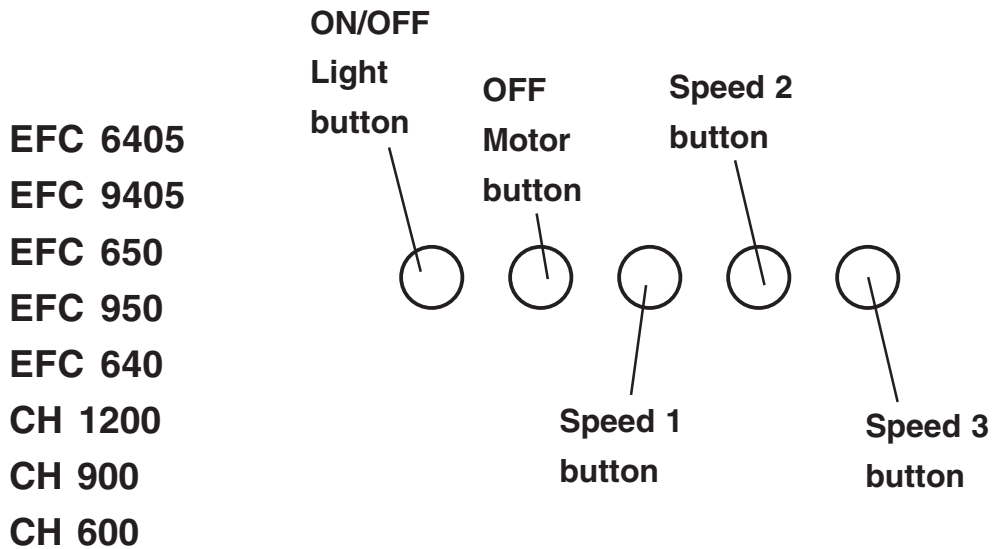
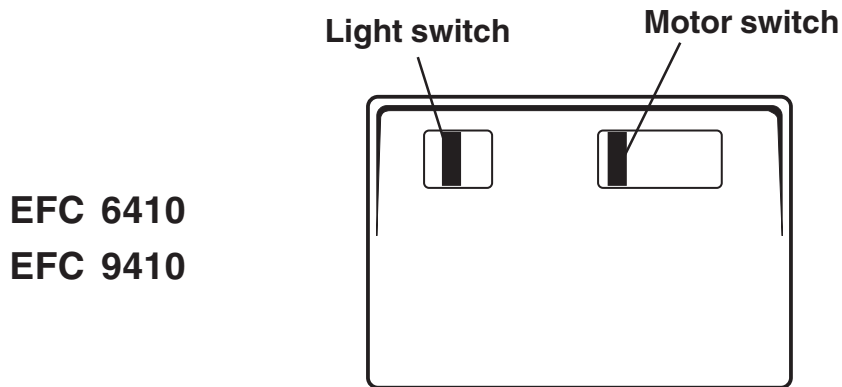

Fig. 2

Control Panel

- Best results are obtained by using a low speed for normal conditions and a high speed when odours are more concentrated. Turn the hood on a few minutes before you start cooking, you will then get an under pressure in the kitchen. The hood should be left on after cooking for about 15 minutes or until all the odours have disappeared. The control switches are located on the unit's front panel:



Correct ventilation

If the cooker hood is to work correctly there must be an under pressure in the kitchen. It is important to keep the kitchen windows closed and have a window in an adjacent room open.

Maintenance and care

- **The hood must always be disconnected from the electricity supply before beginning any maintenance work.**

Cleaning the hood

- Clean the outside of the hood using a damp cloth and a mild detergent.
- Never use corrosive, abrasive or flammable cleaning products.
- Never insert pointed objects in the motor's protective grid.
- Wash the outside surfaces using a delicate detergent solution. Never use caustic detergents or abrasive brushes or powders.
- Only ever clean the switch panel and filter grille using a damp cloth and delicate detergents.
- It is extremely important to clean the unit and change the filters at the recommended intervals. Failure to do so will cause grease deposits to build up that could constitute a fire hazard.

Metal grease filters

- The purpose of the grease filters is to absorb grease particles which form during cooking and they **must** always be used, either in the external extraction or internal recirculation function. Attention: the metal grease filters must be removed and washed, either by hand or in the dishwasher, every four weeks.

Removing the metal grease filters

- Push it towards the back of the unit and then pull it down and out. **Fig. 3.**

Hand washing

Soak grease filters for about one hour in hot water with a grease-loosening cleaner, then rinse off thoroughly with hot water. Repeat the process if necessary. Refit the grease filters when they are dry.

Dishwasher

Place grease filters in the dishwasher. Select most powerful washing programme and highest temperature, at least 65°C. Repeat the process. Refit the grease filters when they are dry.

When washing the metal grease filter in the dishwasher a slight discolouration of the filter can occur, this does not have any impact on its performance.

- Clean the inner housing using a hot detergent solution only (never use caustic detergents, abrasive powders or brushes).

Warning

- Failure to observe the instructions on cleaning the unit and changing the filters will cause a fire hazard. You are therefore strongly recommended to follow these instructions.
- The manufacturer declines all responsibility for any damage to the motor or any fire damage linked to inappropriate maintenance or failure to observe the above safety recommendations.

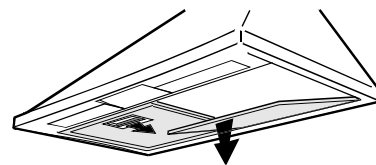

Fig. 3

Charcoal filter

- The charcoal filter should only be used if you want to use the hood in the recirculation function.
- To do this you will need an original ELECTROLUX charcoal filter (available from your local Service Force Centre).
- This filter cannot be cleaned or reused.
- **As a general rule, the activated charcoal filter should be changed once every four months.**
- **Fitting — Fig. 4**
Fit one charcoal filter on the left and one on the right so to cover the plastic grids that protect the fan wheel, then turn clockwise the central handle of the charcoal filter.
- **To remove** proceed in the reverse order.
- Always specify the hood model code number and serial number when ordering replacement filters. This information is shown on the registration plate located on the inside of the unit.
- The charcoal filter can be ordered from your local ELECTROLUX Service Force Centre.

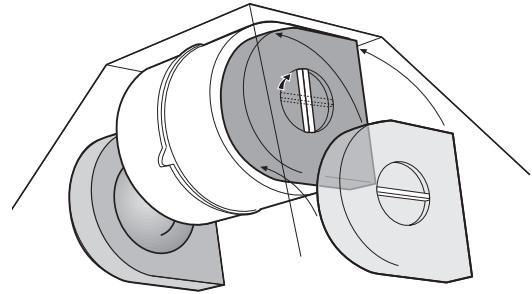

Fig. 4

Changing the light bulb

- Disconnect the cooker hood from the main supply.
- Remove the lamp cover.
- Replace the old bulb with a new one of the same type.
- Remount the lamp cover.
- If the light does not come on, make sure the bulb has been inserted in correctly before contacting your local Service Force Centre.

Changing the light bulb - only models EFC 9405-9414 - 6405-6414

- Disconnect the cooker hood from the main supply.
- Remove the lamp cover, use a flat bladed screw driver as a lever. **Fig. 5.**
- Replace the old bulb with a new one of the same type.
- Refit the lamp cover.
- If the light does not come on, make sure the bulb has been inserted correctly before contacting your local Service Force Centre.

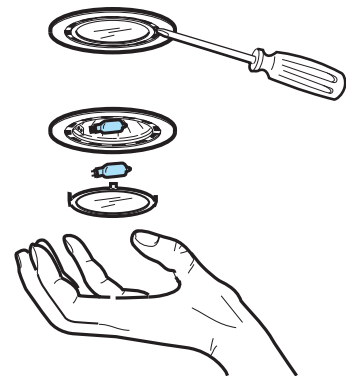

Fig. 5

What to do if

If your appliance fails to work properly please carry out the following checks.

Symptom	Solution
The cooker hood will not start...	Check that: The hood is connected to the electricity supply. Check that a fan speed has been selected
The cooker hood is not working	Check that: The fan speed is set high enough for the task. The grease filters are clean. The kitchen is adequately vented to allow the entry of fresh air. If set up for recirculation, check that the charcoal filter is still effective. If set up for extraction, check that the ducting and outlets are not blocked.
The cooker hood has switched off during operation...	The safety cut-out device has been tripped. Turn off the hob and then wait for the device to reset. If the hood has been installed below the heights indicated in the installation instructions the motor will cut-out frequently which will damage the hood.

If after all these checks, the problem persists, contact your local Service Force Centre, quoting the model and serial number.

Please note that it will be necessary to provide proof of purchase for any in-guarantee service calls.

In-guarantee customers should ensure that the above checks have been made as the engineer will make a charge if the fault is not a mechanical or electrical breakdown.

Special accessories*

Charcoal filter KF825

E-Nr. 942 118 627

* Not available in UK, please contact your local Service Force Centre.

Technical Specifications

Model	Dimensions			Lighting	Grease filter	Power absorption	Electrical connection
	Height	Width	Depth				
EFC 6410	87,5-111,6	59,9	51,5	2 x 40W	2	250 W	220-240 V
EFC 6414	84-117	59,9	51,5	2 x 20W	2	200 W	220-240 V
EFC 9410	87,5-111,6	89,9	51,5	2 x 40W	3	250 W	220-240 V
EFC 9414	84-117	89,9	51,5	2 x 20W	3	200 W	220-240 V
EFC650	87,5-111,6	59,9	51,5	2 x 40W	2	250 W	230 V
EFC950	87,5-111,6	89,9	51,5	2 x 40W	3	250 W	230 V
EFC640	77,2-97,2	60	51,5	2 x 40W	2	210 W	220-230 V
EFC 9405	64-100,5	90	51,5	2 x 20W	3	230 W	220-230 V
EFC 6405	64-100,5	60	51,5	2 x 20W	2	230 W	220-230 V
CH 1200	87,5-111,6	119,9	51,5	2 x 40W	4	250 W	230 V
CH900	87,5-111,6	89,9	51,5	2 x 40W	3	250 W	230 V
CH600	87,5-111,6	59,9	51,5	2 x 40W	2	250 W	230 V

Subject to change without notice.

Technical assistance service (not for UK)

You are welcome to telephone our technical assistance service (see list of technical assistance centres) whenever you need information or in the unlikely event of a fault.

For service in Australia call 1300 650 020.

When calling, please be ready to specify:

1. **The model code number**
2. **The serial number (E-Nr.)**
3. **The manufacturing number (F-Nr.)**

This information is shown on the registration plate inside the unit behind the grease filter.

We reserve the right to change specifications and colours as a result of our policy of continuing technological development.

Service and spare parts for UK



In the event of your appliance requiring service, or if you wish to purchase spare parts, contact your local AEG Service Force Centre by telephoning: **08705 929 929**

Your telephone call will be automatically routed to the Service Centre covering your post code area. For the address of your local Service Force Centre and further information about Service Force, please visit the website at www.serviceforce.co.uk

Please ensure that you have read the section „What to do if...“ as the engineer will make a charge if the fault is not a mechanical or electrical breakdown even the appliance is under warranty. **Please note that proof of purchase is required for in-guarantee service calls.**

Help us to help you

Please determine your type of enquiry before writing or telephoning.

When you contact us we need to know:

- Your name
- Address and post code
- Telephone number
- Clear and concise details of the fault
- Name and model of the appliance*
- E number*

* This information can be found on the rating plate, which can be seen when the grease filters are removed.

CUSTOMER CARE DEPARTMENT

For general enquiries concerning your Electrolux appliance or for further information on Electrolux products, please contact our Customer Care Department by letter or telephone at the address below or visit our website at www.electrolux.co.uk

Customer Care Department

Electrolux

55-77 High Street

Slough

Berkshire

SL1 1DZ

08705 950950 (*)

* calls to this number may be recorded for training purposes.

Guarantee Conditions

Standard guarantee conditions

We, Electrolux, undertake that if within 12 months of the date of the purchase this Electrolux appliance or any part thereof is proved to be defective by reason only of faulty workmanship or materials, we will, at our option repair or replace the same FREE OF CHARGE for labour, materials or carriage on condition that:

The appliance has been correctly installed and used only on the electricity supply stated on the rating plate.

The appliance has been used for normal domestic purposes only, and in accordance with the manufacturer's instructions.

The appliance has not been serviced, maintained, repaired, taken apart or tampered with by any person not authorised by us.

All service work under this guarantee must be undertaken by an Electrolux Service Force Centre. Any appliance or defective part replaced shall become the Company's property.

This guarantee is in addition to your statutory and other legal rights.

Home visits are made between **8.30am and 5.30pm** Monday to Friday.

Visits may be available outside these hours in which case a **premium** will be charged.

Exclusions

This guarantee does not cover:

Damage or calls resulting from transportation, improper use or neglect, the replacement of any light bulbs or removable parts of glass or plastic.

Costs incurred for calls to put right an appliance which is improperly installed or calls to appliances outside the European Community (EC) or European Free Trade Area.

Appliances found to be in use within a commercial environment, plus those which are subject to rental agreements.

Products of Electrolux manufacture which are not marketed by Electrolux.

European Guarantee

If you should move to another country within Europe then your guarantee moves with you to your new home subject to the following qualifications:

The guarantee starts from the date you first purchased your product.

The guarantee is for the same period and to the same extent for labour and parts as exists in the new country of use for this brand or range of products.

This guarantee relates to you and cannot be transferred to another user.

Your new home is within the European Community (EC) or European Free Trade Area.

The product is installed and used in accordance with our instructions and is only used domestically, i.e. a normal household.

The product is installed taking into account regulations in your new country.

Before you move please contact your nearest Customer Care centre, listed below, to give them details of your new home. They will then ensure that the local Service Organisation is aware of your move and able to look after you and your appliances.

France	Senlis	+33 (0)3 44 62 20 13
Germany	Nürnberg	+49 (0)800 234 7378
Italy	Pordenone	+39 (0) 800 117511
Sweden	Stockholm	+46 (0)20 78 77 50
UK	Slough	+44 (0) 1753 219898

Installation

Unpacking

Check that the cooker hood is not damaged. Transportation damages should immediately be reported to the company responsible for transportation.

Damages, faults and any missing parts should immediately be reported to the retailer.

Take care of the packing materials so that small children cannot play with them.

Location

The hood is to be mounted on the wall.

When installed, the hood must be not less than 65 cm. above electric burners or 75 cm. above gas or mixed-fuel burners (fig. 7).

Electrical connection (not for UK)

Safety warnings for the electrician

Before connecting the appliance to the power supply, check that the voltage indicated on the rating plate corresponds to the mains power supply available. Appliances fitted with a plug can be connected to any standard power socket within easy access.

Should it be necessary to provide a fixed connection, the hood must only be installed by an electrician authorised by the local electricity board. When installing, a double pole switch with a distance of at least 3 mm between contacts must be provided.

Fixed connection of the appliance must only be carried out by an authorised electrician.

Electrical connection for UK only

Safety warnings for the electrician

Connect the hood to the mains supply via a double pole switch which has 3 mm minimum separation between the contacts.

The switch must be accessible at all times.

The following is valid in the United Kingdom only:

- the wire which is coloured blue must be connected to the terminal which is marked with the letter N or coloured black, -
- the wire which is coloured brown must be connected to the terminal which is marked with the letter L or coloured red.

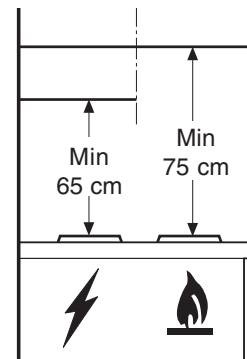

Fig. 7

Installation

Wall unit mounting - Fig. 8

- Put the template onto the wall (1) and drill two Ø12mm holes (2).
- Fit two hooks (3) on the drilled holes.
- Remove the metal filters (4) and hang the hood on the hooks and adjust the position of the hood using the two screws on the bottom of the hooks (5).
- Depending on the model, mark 2 or 4 points (6). Remove the hood and drill 2 or 4 Ø8mm holes on the marked points. Fit 2 or 4 Ø8mm wall dowels, Hang again the hood and fix the hood definitively with 2 or 4 screws 5X45 (7).
- Fix the chimney support (8) with two screws 5 x 45 mm and two wall dowels on the wall close to the ceiling.
- **For the extraction version:** Fit the connection ring (S) on the top of the hood with two screws Ø 3,5 x 6,5 mm (9S) then fit an exhausting pipe long enough to reach the outside (10S).
- **For the recirculation version:** Fix definitively the deflector (K) on the top of the hood with two screws Ø 3,5 x 6,5 mm (9K).
- Prepare the electric connection (11) (see relative chapter).
- Fit the chimney (12) and fix it on the chimney support with two screws 3,0 x 9 mm (13). The lower part of the chimney must be slid down and inserted on the housing on the upper part of the hood (14).
- Fit the two grids (15) on both sides of the chimney.

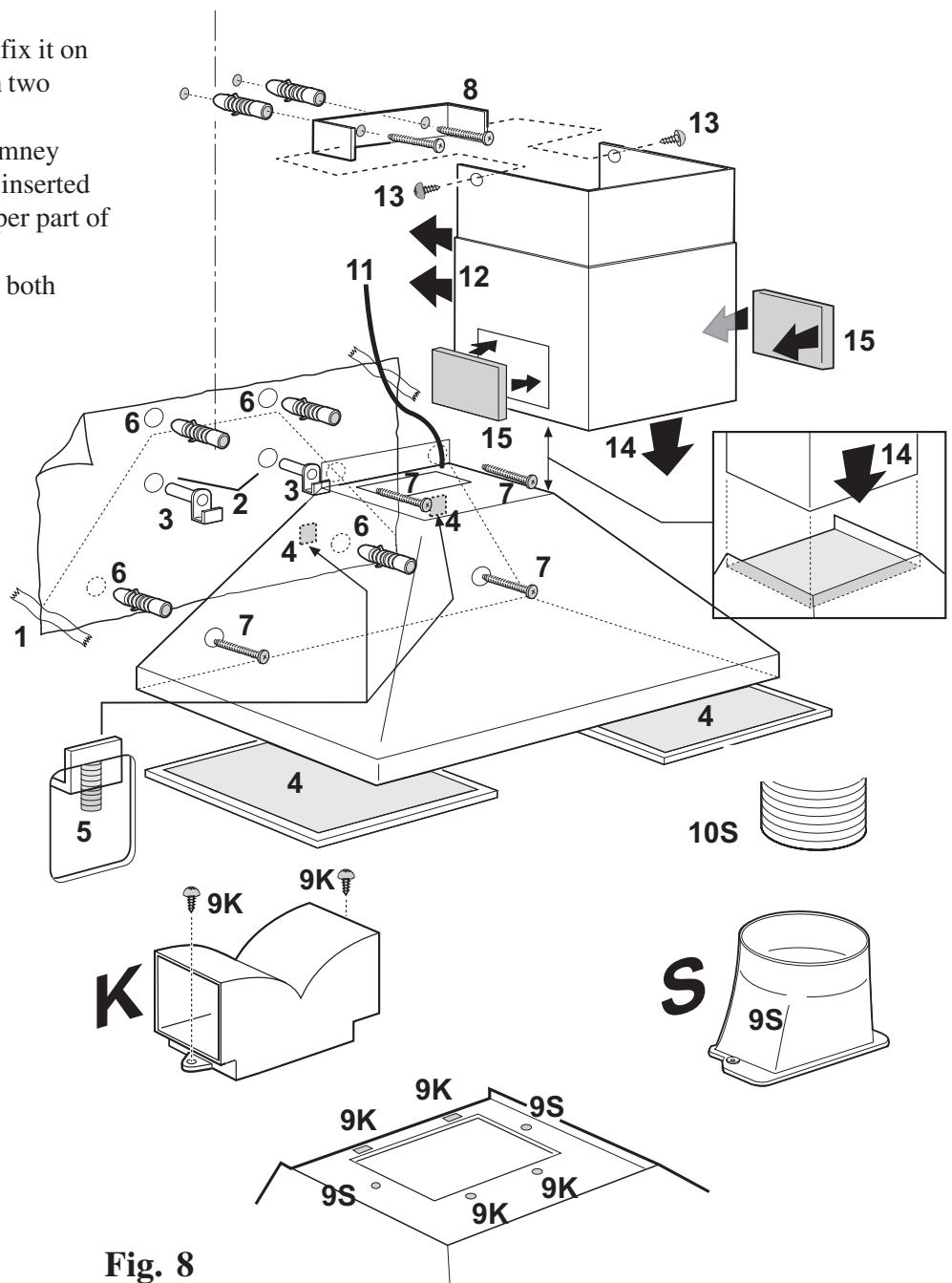

Fig. 8

Electrolux

 **The Electrolux Group.** The world's No.1 choice.

The Electrolux Group is the world's largest producer of powered appliances for kitchen, cleaning and outdoor use. More than 55 million Electrolux Group products (such as refrigerators, cookers, washing machines, vacuum cleaners, chain saws and lawn mowers) are sold each year to a value of approx. USD 14 billion in more than 150 countries around the world.

This file has been downloaded from:

www.UsersManualGuide.com

User Manual and User Guide for many equipments like mobile phones, photo cameras, mother board, monitors, software, tv, dvd, and othes..

Manual users, user manuals, user guide manual, owners manual, instruction manual, manual owner, manual owner's, manual guide, manual operation, operating manual, user's manual, operating instructions, manual operators, manual operator, manual product, documentation manual, user maintenance, brochure, user reference, pdf manual